

TrakLine™ Roll High Performance Door

Improve productivity, performance and efficiency with Rite-Hite's TrakLine Roll Door.

The TrakLine Roll Door from Rite-Hite Doors gives you all the benefits of high-speed operation and an exceptional lifetime value. Its rapid operating speed and automatic closing allow personnel and equipment to move through quickly for optimum productivity. If impacted, the TrakLine Roll Door instantly releases from the flexible track to help avoid damage and downtime. The door automatically re-feeds the curtain into the track, so you can continue efficient operation. The durable lightweight curtain helps protect your personnel and equipment from impact damage.

Fast opening and closing speed

Opening at 40" per second (1 m/sec) helps improve your operating efficiency.

Innovative V-Flex™ Curtain Release System

This helps curtain to withstand impact, minimizing damage and downtime.

Communication

Rite-Hite Doors has a series of light communication products to help reduce common collision accidents between forklifts and pedestrians. LED Countdown, LED Pre-Announce and LED Virtual Vision available.

Opti-Vu BY RITE-HITE An intuitive digital tool for data-driven decision making

More than just sensors and data, the Opti-Vu™ platform monitors equipment, captures events, synchronizes vital information and facilitates data-driven behavioral and process change (subscription & additional hardware required).

Simple, low maintenance design

With no heavy bottom bars, reversing edges or coil cords

Reinsertion System

Automatically refeeds curtain after impact to help eliminate downtime.

Full-width vision panel

Provides enhanced visibility for added safety.

Lightweight curtain design

Helps protect personnel, cargo and equipment.



Graphic User Interface (GUI)

Specifications

Speed

Opens and closes up to 40"/sec (1 m/sec)

Size

Minimum – 5'0" w x 7'0" h (1525 mm x 2135 mm)

Maximum – 12'0" w x 14'0" h (3650 mm x 4265 mm)

Bottom edge

Lightweight bottom enclosed in fabric curtain. Door releases upon impact and automatically refeeds into the track. No junction box or coil cords are attached to bottom edge.

Curtain material

Curtain made of 25 oz. PVC coated polyester fabric and comes complete with an 18" (457 mm) high full-width vision panel. Standard curtain colors: blue and gray.

Sealing

Fabric top seal. Fabric loop seals bottom edge at the floor.

Side frames

Side frames, 14" (355 mm) projection x 5" (127 mm) wide, are formed 14 gauge steel with black polyurethane paint and black corrugated polyethylene covers. Flexible track is 5" (127 mm) wide and is constructed of heavy-duty black polyester fabric. For two-way breakaway, flexible track is 5" (127 mm) in opening on each side. For one-way breakaway, additional 5 3/8" (136 mm) of side clearance is required for track (10 3/8" (263 mm) total per side). Auto re-feed mechanism constructed of polyethylene material.

Electrical requirements

Three-Phase – 208V, 230V, 400V (50Hz), 460V, 575V

Roller tube

4" (101 mm) diameter, 13 gauge steel tube mounted on two precision self-aligning flange bearings.

Drive system

1 HP, 1650 rpm motor with a 12:1 gearbox reduction is controlled i-COMM™ 3 Digital Controller.

Graphic User Interface (GUI)

Industry's only 7" (178 mm) LCD touch screen interface that provides increased safety by allowing an individual to simply access the control box settings without wearing the necessary PPE often required for accessing a live electrical panel.

Control box

- » i-COMM™ 3 Digital Controller, variable frequency drive.
- » Pre-wired and factory tested.
- » Standard fiberglass NEMA 4X.

Safety features

Lightweight curtain design and breakaway capability help protect against impact damage and eliminate entrapment concerns. Full-width vision standard. Two internally mounted reversing photo eyes continuously monitor the door opening. Automatic re-feed helps eliminate ergonomic reattachment concerns.

Limited warranty

Five (5) Year for motor, brake and gearbox.
Two (2) Year on all mechanical and electrical parts.
One (1) Year labor.

TRAKLINE™ ROLL DOOR

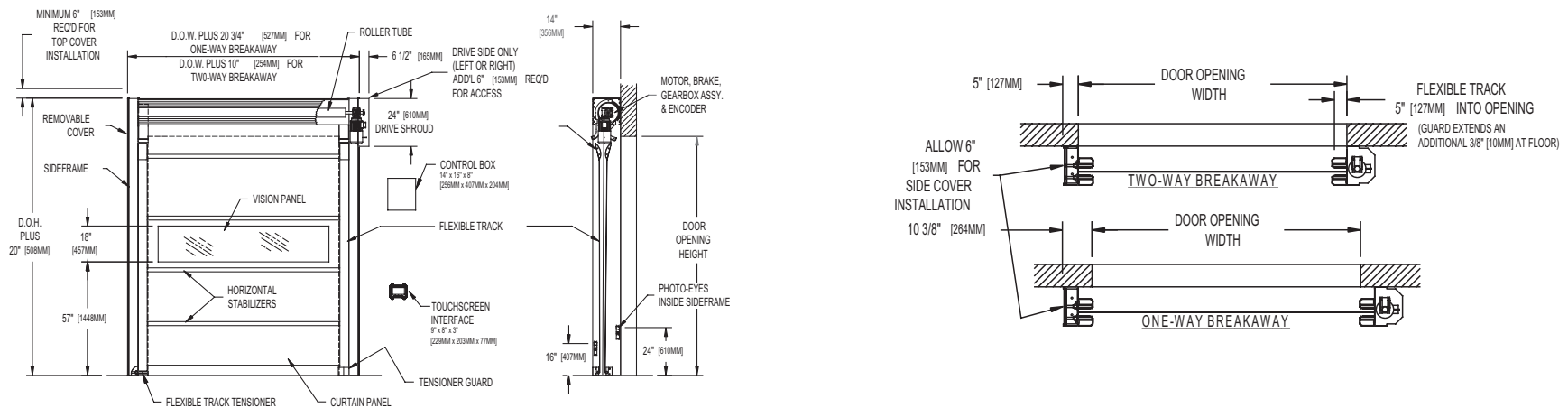

D20TRSS0121G1

8900 North Arbon Drive
Milwaukee, WI 53223, USA

P 414-355-2600 (800-456-0600)

F 414-355-9248

Rite-Hite®, TrakLine™, V-Flex™, i-COMM™ and Opti-Vu™ are trademarks of the Rite-Hite Holding Corporation. Rite-Hite products may be covered by one or more U.S. Patents with other U.S. and foreign patents pending. Rite-Hite reserves the right to make product improvements without prior notice. Manufactured by: Rite-Hite Industrial Door Corporation and Rite-Hite Digital Solutions.

www.ritehite.com